

# TANTALUM CAPACITORS

Type 251



In order to meet the user need of miniaturization and high performance of mobile communication equipment, we have developed the fillet-less surface mounted tantalum chip capacitor which is considered for not only miniaturization / low profile but also mounting area.

Tantalum chip capacitors are used in digital mobile communication equipment, such as mobile phone and PHS, and mobile AV equipment, such as digital video camera, digital still camera and mini-disk player. The tantalum chip capacitors corresponding fillet-less surface mounting will contribute to the micro-miniaturizing and higher performance of these mobile multimedia equipment.

## FEATURES

1. Original face-down terminal structure makes possible of the miniaturization of components and also mounting area because land dimensions can be designed almost the same size as the terminal. Also, as it can form micro fillet, checking at mounting is possible.
2. In addition to the 1608 and 2012 size, 3216L and 3528L size are added to the series. These correspond to a wide range capacitance of 4.7-220 $\mu$ F.
3. Standardized the height of the product to 1.1 mm (low profile) for all 2012 size to 3528L size.
4. The most suitable for high performance miniaturized mobile equipment such as DVC, DSC, mobile phone, and PHS.
5. Type 251's M case (face-down terminal, 1608 size) and S case (face-down terminal, 2012 size) are registered products with JEITA / Electronic Devices Registration Center's registration system of surface-mount devices.
6. Lead free products.

## CHARACTERISTICS

| ITEM                  | CHARACTERISTICS   |
|-----------------------|---|
| Failure rate level    | 1%/1000h (M)  |
| Operating temperature | -55 ~ +125°C (voltage derating when exceeding +85°C)<br>When +125°C, 2/3XRV |
| Rated voltage         | 4-6.3-10 VDC  |
| Capacitance range     | 4.7 ~ 220 $\mu$ F   |
| Capacitance tolerance | $\pm$ 20%(M)  |

## CATALOG NUMBERS AND RATINGS

Table-1

| Catalog number (1)  | Rated Voltage VDC | Surge voltage VDC |       | Capacitance $\mu$ F | Tolerance $\pm$ % | Case Code (2) | Max DC Lct. $\mu$ A |      |       | Max dissipation factor |       |      |       | ESR $\Omega$ 100kHz |
|---------------------|-------------------|-------------------|-------|---------------------|-------------------|---------------|---------------------|------|-------|------------------------|-------|------|-------|---------------------|
|                     |                   | 85°C              | 125°C |                     |                   |               | 20°C                | 85°C | 125°C | -55°C                  | 20°C  | 85°C | 125°C |                     |
| 251 M 4001 226 M _1 | 4                 | 4.6               | 3     | 22                  | 20                | M             | 0.9                 | 18   | 22    | 0.30                   | 0.106 | 0.30 | 0.30  | 4                   |
| 251 M 4001 476 M _1 | 4                 | ↓                 | ↓     | 47                  | 20                | S             | 1.9                 | 38   | 47    | 0.30                   | 0.15  | 0.30 | 0.30  | 4                   |
| 251 M 4001 107 M _1 | 4                 | ↓                 | ↓     | 100                 | 20                | A             | 4                   | 80   | 100   | 0.30                   | 0.15  | 0.30 | 0.03  | 2                   |
| 251 M 4001 227 M _1 | 4                 | ↓                 | ↓     | 220                 | 20                | B             | 8.8                 | 176  | 220   | 0.30                   | 0.15  | 0.30 | 0.03  | 1                   |
| 251 M 6301 106 M _1 | 6.3               | 7.2               | 4.8   | 10                  | 20                | M             | 0.6                 | 6    | 7.9   | 0.15                   | 0.08  | 0.15 | 0.15  | 8                   |
| 251 M 6301 226 M _1 | 6.3               | ↓                 | ↓     | 22                  | 20                | S             | 1.4                 | 14   | 17    | 0.16                   | 0.08  | 0.16 | 0.16  | 4                   |
| 251 M 6301 336 M _1 | 6.3               | ↓                 | ↓     | 33                  | 20                | S             | 2.1                 | 21   | 26    | 0.30                   | 0.15  | 0.30 | 0.30  | 4                   |
| 251 M 6301 476 M _1 | 6.3               | ↓                 | ↓     | 47                  | 20                | A             | 3.0                 | 30   | 37    | 0.20                   | 0.10  | 0.20 | 0.20  | 2                   |
| 251 M 6301 107 M _1 | 6.3               | ↓                 | ↓     | 100                 | 20                | B             | 6.3                 | 63   | 79    | 0.20                   | 0.10  | 0.20 | 0.20  | 1                   |
| 251 M 6301 157 M _1 | 6.3               | ↓                 | ↓     | 150                 | 20                | B             | 9.5                 | 95   | 118   | 0.30                   | 0.15  | 0.30 | 0.30  | 1                   |
| 251 M 1002 475 M _1 | 10                | 11.5              | 7.6   | 4.7                 | 20                | M             | 0.5                 | 5    | 6.3   | 0.12                   | 0.06  | 0.12 | 0.12  | 10                  |
| 251 M 1002 106 M _1 | 10                | ↓                 | ↓     | 10                  | 20                | S             | 1                   | 10   | 13    | 0.16                   | 0.08  | 0.16 | 0.16  | 4                   |
| 251 M 1002 156 M _1 | 10                | ↓                 | ↓     | 15                  | 20                | S             | 1.5                 | 15   | 19    | 0.16                   | 0.08  | 0.16 | 0.16  | 4                   |
| 251 M 1002 226 M _1 | 10                | ↓                 | ↓     | 22                  | 20                | A             | 2.2                 | 22   | 28    | 0.20                   | 0.10  | 0.20 | 0.20  | 2                   |
| 251 M 1002 476 M _1 | 10                | ↓                 | ↓     | 47                  | 20                | B             | 4.7                 | 47   | 59    | 0.20                   | 0.10  | 0.20 | 0.20  | 1                   |
| 251 M 1002 686 M _1 | 10                | ↓                 | ↓     | 68                  | 20                | B             | 6.8                 | 68   | 85    | 0.20                   | 0.10  | 0.20 | 0.20  | 1                   |

(1) \_1 : No code for single item. Put code "R" for taping specification.

(2) A and B Case are under development.

## DIMENSIONS

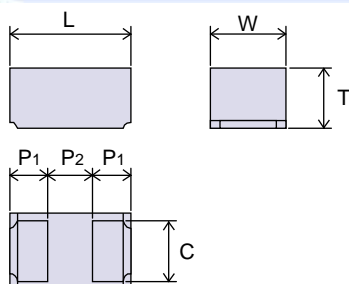

| Case Size | Case Code | L $\pm$ 0.1 | W $\pm$ 0.1 | T $\pm$ 0.1 | P1 $\pm$ 0.1 | P2 $\pm$ 0.1 | C $\pm$ 0.1 |
|-----------|-----------|-------------|-------------|-------------|--------------|--------------|-------------|
| M         | 1608      | 1.6         | 0.85        | 0.8         | 0.5          | 0.65         | 0.75        |
| S         | 2012      | 2.0         | 1.25        | 1.1         | 0.5          | 1.05         | 0.9         |
| A         | 3216L     | 3.2         | 1.6         | 1.1         | 0.8          | 1.65         | 1.2         |
| B         | 3528L     | 3.5         | 2.8         | 1.1         | 0.8          | 1.95         | 2.2         |

(mm)

## FREQUENCY CHARACTERISTICS

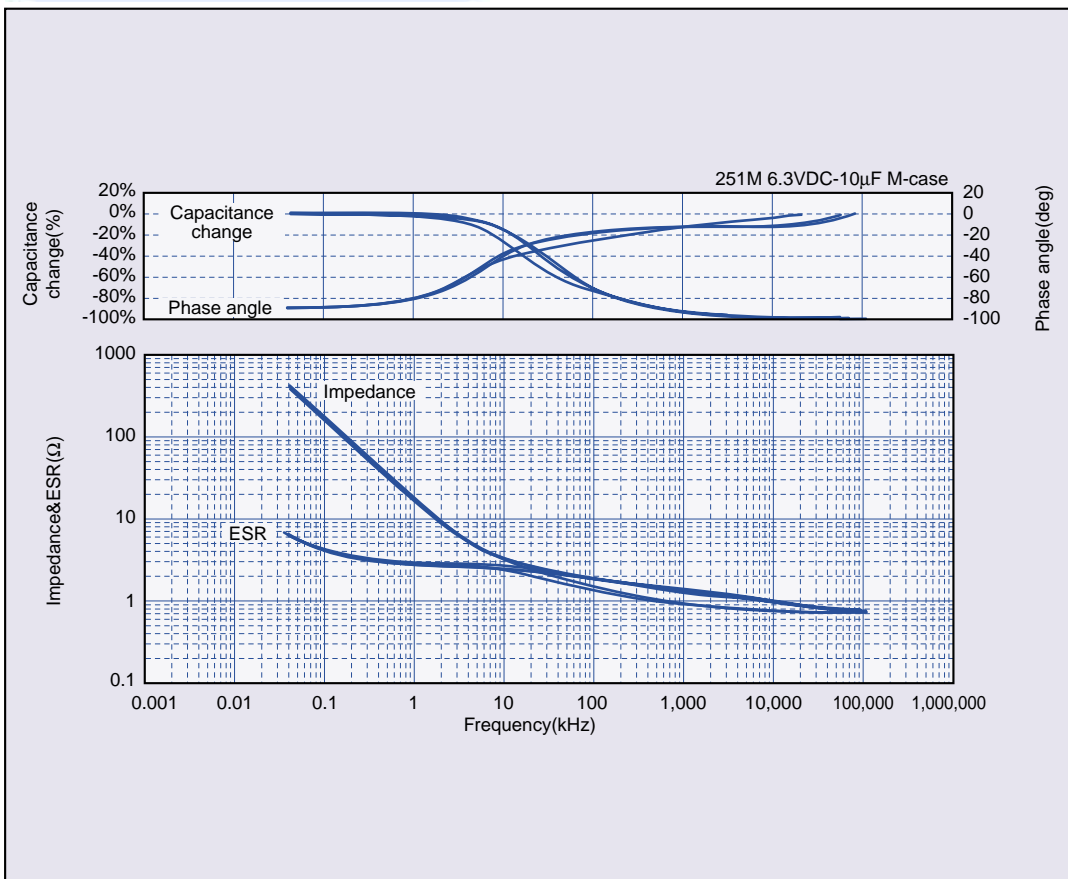

## TEMPERATURE CHARACTERISTICS

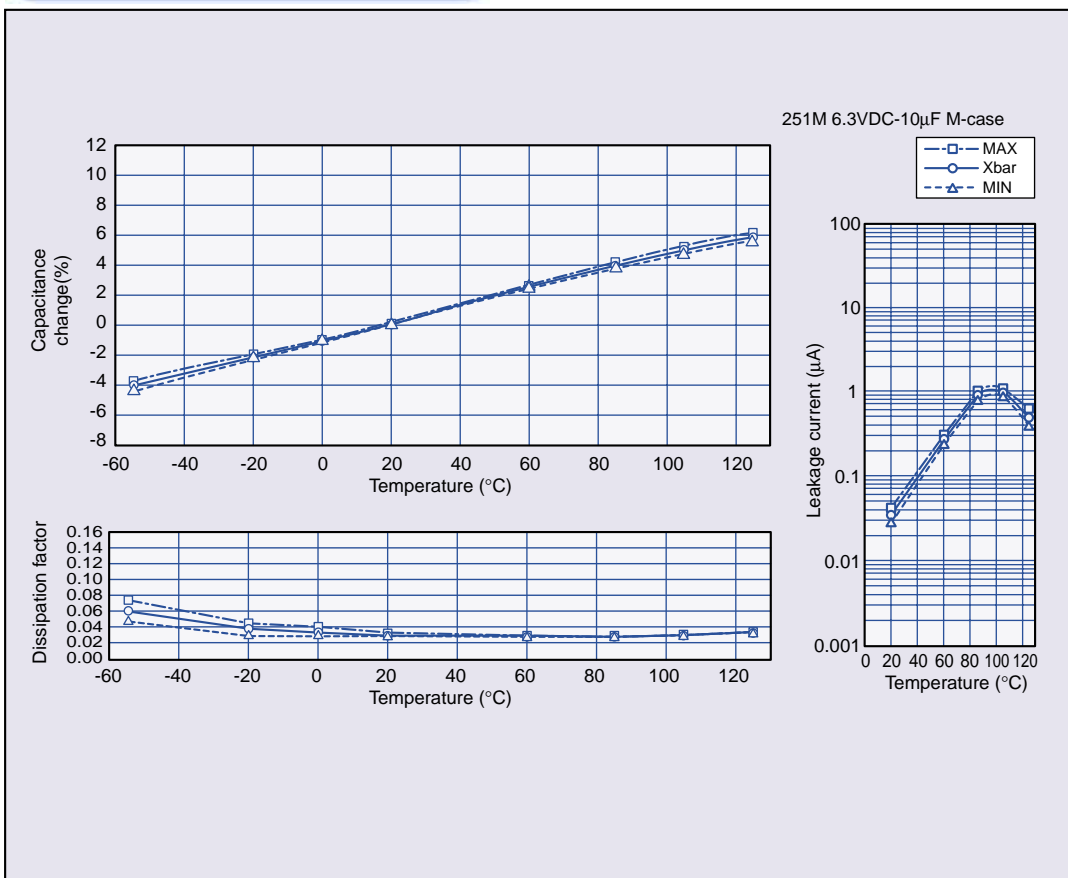

## PERFORMANCE AND TEST METHOD

| NO | TEST ITEM                                   |   | PERFORMANCE   | TEST METHOD  |   |
|----|---|---|---|--|---|
| 1  | Leakage Current ( $\mu$ A)                  |   | Shall not exceed 0.01CV or 0.5 whichever is greater   | Applied voltage: Rated voltage for 5 minutes   |   |
| 2  | Capacitance                                 |   | Shall be within tolerance of the nominal value specified.   | Frequency: 120Hz $\pm$ 20%<br>Voltage: 0.5Vrms+1.5-2VDC  |   |
| 3  | Dissipation Factor                          |   | Shall not exceed the value in Table 1.  |  |   |
| 4  | Characteristics at High and Low Temperature | Step 1  | Leakage Current ( $\mu$ A)<br>Capacitance<br>Dissipation Factor   | Shall not exceed the value in No 1.<br>Shall be within tolerance of the nominal value specified.<br>Shall not exceed the value in Table 1.   | Temperature: 20 $\pm$ 2 $^{\circ}$ C  |
|    |   | Step 2  | Capacitance<br>Dissipation Factor   | Within -15/+0% of the value in Step 1.<br>Shall not exceed the value in Table 1.   | Temperature: -55 $\pm$ 3 $^{\circ}$ C   |
|    |   | Step 3  | Leakage Current ( $\mu$ A)<br>Capacitance<br>Dissipation Factor   | Shall not exceed the value in No 1.<br>Within $\pm$ 2% of the value in Step 1.<br>Shall not exceed the value in Table 1.   | Temperature: 20 $\pm$ 2 $^{\circ}$ C  |
|    |   | Step 4  | Leakage Current ( $\mu$ A)<br>Capacitance<br>Dissipation Factor   | Shall not exceed 0.1CV or 5 whichever is greater.<br>For rated voltage 4V or less, shall not exceed 0.25CV.<br>Within -0/+10% of the value in Step 1.<br>Shall not exceed the value in Table 1.  | Temperature: 85 $\pm$ 2 $^{\circ}$ C  |
|    |   | Step 5  | Leakage Current ( $\mu$ A)<br>Capacitance<br>Dissipation Factor   | Shall not exceed 0.125CV or 6.3 whichever is greater.<br>For rated voltage 4V or less, shall not exceed 0.25CV.<br>Within -0/+15% of the value in Step 1.<br>Shall not exceed the value in Table 1.  | Temperature: 125 $\pm$ 2 $^{\circ}$ C<br>Voltage: 125 $^{\circ}$ C voltage derating |
|    |   | Step 6  | Leakage Current ( $\mu$ A)<br>Capacitance<br>Dissipation Factor   | Shall not exceed the value in No 1.<br>Within $\pm$ 2% of the value in Step 1.<br>Shall not exceed the value in Table 1.   | Temperature: 20 $\pm$ 2 $^{\circ}$ C  |
| 5  | Surge                                       | Leakage Current ( $\mu$ A)<br>Capacitance<br>Dissipation Factor<br>Visual Examination | Shall not exceed the value in No 1.<br>Within $\pm$ 15% of the value before the test.<br>Shall not exceed the value in Table 1.<br>There shall be no evidence of mechanical damage.   | Temperature, Applied voltage: half of the samples each<br>•85 $\pm$ 2 $^{\circ}$ C, rated voltage $\times$ 1.15<br>•125 $\pm$ 2 $^{\circ}$ C, 2/3 $\times$ rated voltage $\times$ 1.15<br>Series protective resistance: 1000 $\Omega$<br>Discharge resistance: 1000 $\Omega$ |   |
| 6  | Shear (formerly adhesion) Test              |   | No exfoliation between lead terminal and board.   | Samples are mounted with the following conditions.<br>•Indirect heating method (reflow)<br>•Temperature: 240 $\pm$ 10 $^{\circ}$ C/Time: 10seconds or less<br>Applied pressure: 5N<br>Duration: 10 $\pm$ 1seconds  |   |
| 7  | Substrate Bending Test                      | Capacitance<br>Visual Examination   | Initial value to remain steady during measurement.<br>There shall be no evidence of mechanical damage.  | Bend: 1mm  |   |
| 8  | Vibration                                   | Capacitance<br>Visual Examination   | Initial value to remain steady during measurement.<br>There shall be no evidence of mechanical damage.  | Frequency range: 10-55Hz<br>Total swing width:1.5mm<br>Vibration direction: 3 directions with mutually right-angled.<br>Duration: 2 hours in each of these mutually perpendicular directions (total of 6 hours)<br>Mounting: Solder terminal to the printed board            |   |
| 9  | Shock (specified pulse)                     |   | There shall be no intermittent contact of 0.5ms or greater, short, or open. Nor shall there be any spark discharge, insulation breakdown, or evidence of mechanical damage.   | Peak acceleration: 490m/s <sup>2</sup><br>Duration: 11ms<br>Wave form: Half-sine   |   |
| 10 | Solderability                               |   | Solder shall stick well on the terminal. (No pinhole, damp, and solder repel)   | Solder temperature: 235 $\pm$ 5 $^{\circ}$ C<br>Dipping time: 2 $\pm$ 0.5seconds<br>Dipping depth: Capacitor terminal shall be dipped into melted solder   |   |
| 11 | Resistance to Soldering Heat                | Leakage Current ( $\mu$ A)<br>Capacitance<br>Dissipation Factor<br>Visual Examination | Shall not exceed the value in No 1<br>Within $\pm$ 15% of the value before the test.<br>Shall not exceed the value in Table 1.<br>There shall be no evidence of mechanical damage.  | IR Reflow<br>Preheat: 130-160 $^{\circ}$ C, approx. 60seconds<br>Reflow: 200 $^{\circ}$ C, <60seconds max 260 $^{\circ}$ C<br>Number of reflow: 2  |   |
| 12 | Rapid Change of Temperature                 | Leakage Current ( $\mu$ A)<br>Capacitance<br>Dissipation Factor<br>Visual Examination | Shall not exceed 2 times value shown in No 1.<br>Within $\pm$ 15% of the value before the test.<br>Shall not exceed 150% of the value in Table 1.<br>There shall be no evidence of mechanical damage.                         | Step 1: -55 $\pm$ 3 $^{\circ}$ C 30 $\pm$ 3minutes<br>Step 2: 25 (-5/+10) $^{\circ}$ C, 3minutes or less<br>Step 3: 125 $\pm$ 2 $^{\circ}$ C, 30 $\pm$ 3minutes<br>Step 4: 25 (-5/+10) $^{\circ}$ C, 3minutes or less<br>Number of cycle: 5                                  |   |
| 13 | Damp heat, Steady state                     | Leakage Current ( $\mu$ A)<br>Capacitance<br>Dissipation Factor<br>Visual Examination | Shall not exceed 2 times value shown in No 1.<br>Within $\pm$ 15% of the value before the test.<br>Shall not exceed 150% of the value in Table 1.<br>There shall be no evidence of mechanical damage. Marking shall be clear. | Temperature: 40 $\pm$ 2 $^{\circ}$ C<br>Moisture: 90-95%R.H.<br>Duration: 500 (-0/+24) hours   |   |
| 14 | Endurance                                   | Leakage Current ( $\mu$ A)<br>Capacitance<br>Dissipation Factor<br>Visual Examination | Shall not exceed 2 times value shown in No 1.<br>Within $\pm$ 15% of the value before the test.<br>Shall not exceed 150% of the value in Table 1.<br>There shall be no evidence of mechanical damage. Marking shall be clear. | Temperature, applied voltage:<br>85 $\pm$ 2 $^{\circ}$ C, DC rated voltage or<br>125 $\pm$ 3 $^{\circ}$ C, 2/3 $\times$ rated voltage<br>Duration: 2000 (-0/+72) hours<br>Series resistance: do not exceed 3 $\Omega$  |   |

## ORDERING INFORMATION

| 251 TYPE      |         | M FAILURE RATE | 6301 RATED VOLTAGE |         | 106 CAPACITANCE |  | M CAPACITANCE TOLERANCE | R STYLE OF REELED PACKAGE |
|---------------|---------|----------------|--------------------|---------|-----------------|--|-------------------------|---------------------------|
| Rated voltage | Marking |                | Capacitance        | Marking |                 |  | Code                    | Anode notation            |
| 4VDC          | 4001    |                | 4.7 $\mu$ F        | 475     |                 |  | $\phi$ 180 Reel         |                           |
| 6.3VDC        | 6301    |                | 10 $\mu$ F         | 106     |                 |  | R                       | Feed hole side: -         |
| 10VDC         | 1002    |                | 15 $\mu$ F         | 156     |                 |  |                         |                           |
|               |         |                | 22 $\mu$ F         | 226     |                 |  |                         |                           |
|               |         |                | 33 $\mu$ F         | 336     |                 |  |                         |                           |
|               |         |                | 47 $\mu$ F         | 476     |                 |  |                         |                           |
|               |         |                | 68 $\mu$ F         | 686     |                 |  |                         |                           |
|               |         |                | 100 $\mu$ F        | 107     |                 |  |                         |                           |
|               |         |                | 150 $\mu$ F        | 157     |                 |  |                         |                           |
|               |         |                | 220 $\mu$ F        | 227     |                 |  |                         |                           |

(Taping Specification)

## MARKING

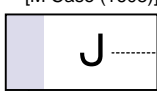
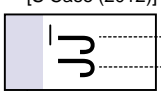
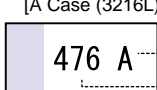
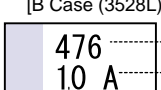
| [M Case (1608)]  | [S Case (2012)]  |
|--|--|
|   |   |
| Rated voltage (1)  | Capacitance (2)  |
| Polarity (anode notation)  | Rated voltage (1)  |
|  | Polarity (anode notation)  |
| [A Case (3216L)]   | [B Case (3528L)]   |
|  |  |
| Manufacturing date code  | Capacitance (3)  |
| Capacitance (3)  | Manufacturing date code  |
| Polarity (anode notation)  | Rated voltage  |
|  | Polarity (anode notation)  |

(1)

|                    |   |     |    |
|--------------------|---|-----|----|
| Rated voltage VDC  | 4 | 6.3 | 10 |
| Rated voltage code | G | J   | A  |

(2)

|                           |   |     |     |     |     |     |
|---------------------------|---|-----|-----|-----|-----|-----|
| Rated capacitance $\mu$ F | 1 | 1.5 | 2.2 | 3.3 | 4.7 | 6.8 |
| Rated capacitance code    | A | E   | J   | N   | S   | W   |

Mark of rated capacitance except above:  $\_ (1/10)$ ,  $\_ (\times 10)$   
(e.g. J indicates 0.22 (J(2.2) $\times$ 1/10))

(3) Refer "ORDERING INFORMATION"

## RECOMMENDED PAD DIMENSIONS

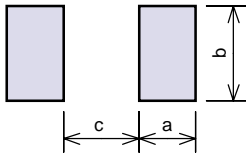

| Case Size | Case Code | a       | b    | c    | Mask thickness |
|-----------|-----------|---------|------|------|----------------|
| M         | 1608      | 0.50min | 0.65 | 0.65 | 100 $\mu$ m    |
| S         | 2012      | 0.50min | 0.8  | 1.05 | 100 $\mu$ m    |
| A         | 3216L     | 0.80min | 1.1  | 1.65 | 100 $\mu$ m    |
| B         | 3528L     | 0.80min | 2.1  | 1.95 | 100 $\mu$ m    |

(mm)

In order to increase the self alignment effect for appropriate soldering, it is recommended that land be almost the same size as terminal of capacitor, and space between lands (c) nearly equal to the space between terminals or slightly smaller.

## CONFIGURATION (M, S CASE)

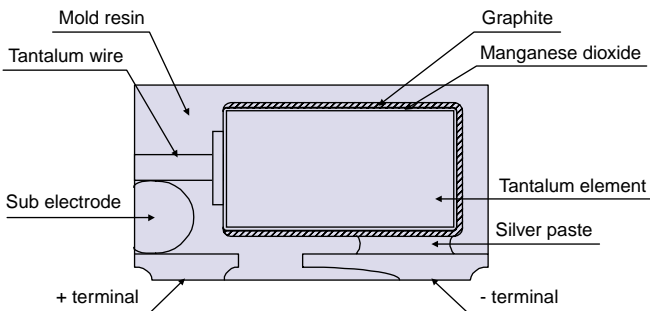

| ITEM              | MATERIAL          | MEMO        |
|-------------------|-------------------|-------------|
| Tantalum element  | Tantalum          |             |
| Tantalum wire     | Tantalum          |             |
| Manganese dioxide | Manganese dioxide |             |
| Graphite          | Carbon            |             |
| Silver paste      | Silver            |             |
| Sub electrode     | Tantalum          |             |
| + terminal        | Nickel alloy      | Tin-plating |
| - terminal        | Nickel alloy      | Tin-plating |
| Mold resin        | Epoxy resin       |             |

# Application Notes for Tantalum Capacitors

## 1. Operating Voltage

Tantalum capacitors shall be operated at the rated voltage or lower.  
**Rated voltage:** Maximum value of DC voltage which can apply continuously to capacitor's terminals at rated temperature  
**Surge voltage:** The voltage which can apply instantaneously to capacitors at rated temperature or maximum high temperature. Also, the voltage which can endure 1000 times cycle through 1000Ω of series resistance for 30 seconds at 6 minutes cycle. When designing the circuit, the equipment's required reliability must be considered and appropriate voltage derating must be performed.

## 2. Applications that contain AC Voltage

- Special attention to the following 3 items.
- (1) The sum of the DC bias voltage and the positive peak value of the AC voltage should not exceed the rated voltage.
  - (2) Reverse voltage should not exceed the allowable values of the negative peak AC voltage (refer page 3).
  - (3) Ripple voltage should not exceed the allowable values (refer page 4).

## 3. Permissible Reverse Voltage

To avoid an increase in failure rate and changes in leakage current, reverse voltage should be kept below the values listed in the following table. In order to avoid the reverse voltage exceeding allowable value, add bias voltage when necessary.

| Ambient Temperature         | 25°C                          | 55°C       | 85°C       | 125°C      |
|-----------------------------|-------------------------------|------------|------------|------------|
| Permissible Reverse Voltage | R. V. × 10%                   | R. V. × 6% | R. V. × 3% | R. V. × 1% |
|                             | or 0.5V whichever is greater. |            |            |            |

Note: The above information in the table applies to circuits with incidental reverse voltage being applied.  
 For constant reverse voltage in a circuit, a non-polar device is always recommended.

## 4. Permissible Ripple Voltage

Permissible ripple voltage is determined by the heat loss of the element and heat radiation of the lead wire, and is influenced by capacitance, ESR, operating temperature, and frequency of ripple. Please consult Matsuo's Engineering Bulletin for details on calculating permissible ripple current values.

## 5. Low Impedance Applications

The failure rate of a low impedance circuit at 0.1Ω/V is about five times greater than that of 1Ω/V circuit. To curtail this higher failure rate, the operating voltage of tantalum capacitors used in low impedance circuits, such as filters for power supplies (particularly switching power supplies) or for noise by-passing, should be derated to less than half of the rated voltage (favorably, 1/3).

## 6. Non Polar Application

Tantalum capacitors can be used as a non-polar unit if two capacitors are connected "BACK-TO-BACK" in a circuit when reverse voltage is applied at more than permissible value or in a purely AC circuit. Please pay attention to the following points when connecting two capacitors "BACK-TO-BACK".

Ripple Voltage: Permissible Ripple Voltage shall not exceed the value allowed for either C<sub>1</sub> or C<sub>2</sub>.

$$\text{Capacitance: } \frac{C_1 \times C_2}{C_1 + C_2}$$

Leakage Current: If terminal A is (+), the Leakage Current will be equal to C<sub>1</sub>'s Leakage Current.  
 If terminal B is (+), the Leakage Current will be equal to C<sub>2</sub>'s Leakage Current.

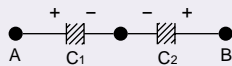

## 7. Soldering

### 7.1. Pre-heating

To obtain optimal reliability, lowering the heat shock during the soldering process is favorable. Capacitors should be pre-heated at 130-160°C for approximately 60 seconds.

### 7.2. Soldering

The body of the capacitor should not exceed 260°C during soldering.

#### (1) Reflow Soldering

Reflow soldering is a process in which the capacitors are mounted on a printed board with solder paste.

Two methods of Reflow Soldering: Direct Heat and Atmospheric Heat

#### - Direct Heat (Hot Plate)

During the Direct Heat method, the capacitor has been positioned on a printed board, which is then placed on a hot plate. The capacitor maintains a lower temperature than the printed board, which in turn stays at a lower temperature than the hot plate.

#### - Atmospheric Heat

#### a) VPS(Vapor Phase Soldering)

During VPS, the printed board is heated by inert liquid with a high boiling point. The temperature of the capacitor's body and the temperature of the printed board are about the same as the atmosphere. Please set this temperature below 240°C.

#### b) Near and Far IR Ray

Due to the heat absorption of the capacitor's body, the internal temperature of the capacitors may be 20-30°C higher than the setting temperature and may exceed 260°C. To prevent the capacitor's internal temperature from exceeding 260°C, temperature of the oven shall be set lower, or perform air or nitrogen circulation (refer to the next item C) at the same time.

#### c) Convection Oven

An infrared ray is the main source of heat in this process. The temperature of the printed board and the capacitors can be maintained at similar level by the circulation of heated air, or inert gas.

#### (2) Soldering Iron

Soldering with a soldering iron cannot be recommended due to the lack of consistency in maintaining temperatures and process times. If this method should be necessary, the iron should never touch the capacitors' terminals, and the temperature of the soldering iron should never exceed 290°C. The application of the iron should not exceed 3 seconds.

#### (3) Please consult Matsuo's Sales Department for other methods.

## 8. Solvent Cleaning

Cleaning by organic solvent may damage capacitor's appearance and performance. However, our capacitors are not effected even when soaked at 20-30°C 2-propanol for 5 minutes. When introducing new cleaning methods or changing the cleaning term, please consult Matsuo's Sales Department.

## 9. Protective Resin Coating

If molded with resin coating after assembly on printed board, the heat generated by resin causes it to harden, and the inner stress caused by temperature change after hardenings may cause failure. Sufficient advance test shall be done before selecting resin or buffer coating.

## 10. Vibration

When a capacitor is dropped to a concrete floor from 1 meter height, approximately 2940m/s<sup>2</sup> shall be applied to the capacitor. Although capacitors are made to withstand this drop test, stress from falling shock can cause damage to the capacitors and may increase the failure rate.

## 11. Ultrasonic Cleaning

Ultrasonic cleaning under severe condition may break terminals. Also, from an electrical characteristics aspect, it is unfavorable. Therefore, please do not use ultrasonic cleaning if possible. If the Ultrasonic cleaning process will be used, please note the following:

- (1) The solvent should not be boiled. (Lower the ultrasonic wave output or use a solvent with the high boiling point)
- (2) The recommended wattage is less than 0.5 watts per cm<sup>2</sup>.
- (3) The cleaning time should be kept to a minimum. Also, samples must be shook. Please consult Matsuo's Sales Department before use.

## 12. Additional Notes

- When connecting two or more capacitors in series, connect the resistors in parallel to share the voltage evenly to each capacitor.
- Cutting of capacitor's wrapping material must not be done because of the limitation of the mounting space.
- During a customer's aging process, voltage should remain under the capacitor's rated voltage at all times.
- Capacitors should never be touched or manipulated while operating.
- Capacitors should not be dismantled.
- When testing capacitors, please examine the power source before conducting tests to insure the tester's polarity. When checking by applying electrode while turning on electricity, please do not touch the polarity of other components.
- In the event of a capacitor burning, smoking, or emitting an offensive smell during operation, please cut the power supply or unplug. Keep away from the burned capacitor.
- When capacitors are shorted, they become very hot and tantalum capacitor elements may ignite. It may burn the printed circuit board and other parts.
- Capacitors should be stored at room temperature under normal humidity and packaged to avoid direct sunlight and dust. Capacitors exceeding shelf life shall be disposed of.
- Equipment with capacitors shall be stored at normal temperature and humidity. If they are operated in a humid environment, they should be moisture proof. Avoid condensation on capacitors. Capacitors shall be coated under the operation in active gasses so that the gasses will not touch the capacitors directly. Capacitors should not be operated in environments containing acids and alkalis.
- When capacitors are disposed of as "scrap" or waste, they should be treated as Industrial Waste since they contain various metals and resin.
- Capacitors submitted as samples should not be used for equipment coming onto the market. We provide samples for only specific purpose (configuration sample, check for electric characteristics, etc.).



**MATSUO ELECTRIC CO., LTD.**

Please feel free to ask our Sales Department for more information of the Tantalum Capacitors.

Head Office 3-5-3 Sennari-cho, Toyonaka-shi, Osaka 561-8558, Japan

Tel : 06-6332-0871

Fax : 06-6331-1386

Export Dep. Takara Bldg., 8-7 Toyotsu-cho, Suita-shi, Osaka 564-0051, Japan

Tel : 06-6337-6450

Fax : 06-6337-6456

USA Matsuo Electronics of America, Inc.  
 2134 Main Street, Suite 200, Huntington Beach, CA 92648

Tel : 714-969-2491

Fax : 714-960-6492

URL <http://www.ncc-matsuo.co.jp/>

Specifications on this catalog are subject to change without prior notice. Also, since this catalog is designed for providing general information, please inquire of our Sales Department to confirm specifications prior to use.